





Linatex Specialty Hose

LINATEX
OUR STRENGTH. YOUR ENDURANCE.

-  MOULDED
-  PROCESS EQUIPMENT
-  SERVICE
-  HOSE
-  SHEET
-  SCREEN MEDIA

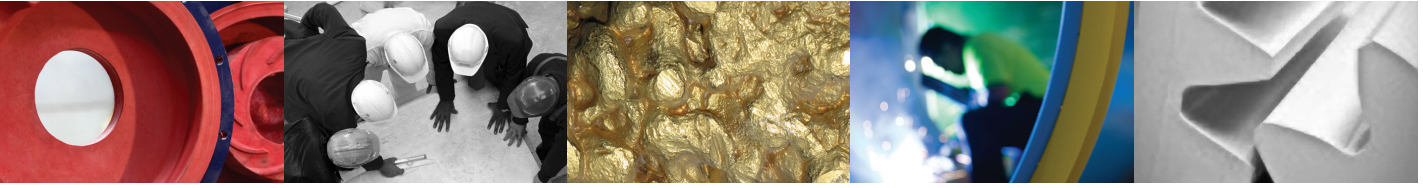

Linatex Hose Systems are expertly built to deliver outstanding wear performance in the most demanding applications.

Linatex Specialty Hose

Linatex is acknowledged around the world as a market leader in the manufacture of premium specialty rubber hose. Our collective global experience and expertise in the design and manufacture of custom made materials handling hose is second to none.

Built to deliver outstanding wear performance in the most demanding applications, Linatex hose products have rightly won a reputation for reliability and long wear life. They are industry compatible with a wide range of processing plants, and are fitted as standard equipment to many leading systems across the globe.

The Linatex Specialty Hose range incorporates slurry and chemical mining hose, dredge hose and a wide variety of preformed bends, reducers and T-pieces all of which are available with a versatile array of end types. Our state of the art computer controlled lathes ensure that the application of material in the hose construction is consistent. This makes for a high quality hose construction that is both robust and reliable.

When you choose to install our Wear Indicator technology, you are taking advantage of over 80 years experience, our cutting edge technology and a step towards improving both the safety and environmental impact of your site.

With sites on every continent and a distribution network unparalleled in the industry, we can deliver application-engineered hose systems to you, wherever you are. Whenever you work with one of our local Linatex representatives, you are supported by the know-how of a global team.

Linatex Specialty Hose

POLYMERS AND LINERS

Linatex Natural Rubber Compounds

Linatex Premium Rubber

Linard Compounds

Linard 60

Linard HDS

Linard HD70

Linagard Compounds

Nitrile

Neoprene OSR

Other Compounds

Natural/SBR

EPDM

Hypalon

Neoprene

Butyl

Natural and synthetic blends used. Other compounds available on request.

RAW MATERIALS

At Linatex we believe that quality raw materials are the key to manufacturing premium specialty hose. When we design and custom build your hose, you can rely on receiving a superior wear resistant hose created with the highest quality rubber compounds (see left), reinforcement cords and end connections.

Wear liner composition is critical to the performance of your hose. With over 80 years industry experience, Linatex has the expertise to select the best composition for your specified application. Our extensive knowledge of wear performance compounds ensures that our products are built to last.

Our hoses are created using traditional reinforcement materials such as nylon or polyester. Alternate materials, such as Kevlar, may also be used. Reinforcement cord materials are selected to complement our designs during the engineering process.

INNOVATION

Linatex is proud to be an industry innovator. Our engineers lead the way in technological advancements, constantly improving our hose products to make your job easier. For example, our unique Wear Indicator technology for Hose is a wireless early warning system that alerts operators to hose wear in highly abrasive materials handling applications. The technology ensures that environmental spills, costly emergency downtime, and health and safety incidents are significantly reduced or eliminated.

DESIGN FEATURES

The unique Linatex red natural rubber compounds provide your project with proven superior wear resistance and extended wear life. This ensures that the lowest total cost of ownership is realised.

Our entire hose range is supported by our extensive technical and design facilities. This allows for full customisation to meet your specific requirements which, in turn, reduces commissioning and installation inefficiencies.

The Linatex Specialty Hose range features:

- Various hardnesses and compounds to suit specific applications
- A variety of standard and custom made bore sizes and lengths
- Specialised end fittings to suit individual applications
- Custom branding and/or colour coding to ensure full and clear identification
- Hose Audit Service provides onsite evaluation/review of all hose issues including suitability and safety
- Independent testing facilities are available
- Experienced field representatives provide onsite assessment and advice
- Cutting edge Linatex Wear Indicator technology provides critical hose monitoring confidence







THE RIGHT HOSE FOR THE JOB

At Linatex we understand that each of our customers has unique needs and specific requirements. We will work closely with you to ensure that you achieve the best hose solution for your site. We will custom design to any size, with hose diameters in excess of 1 m/40 in and lengths up to 15 m/50 ft.

Linatex hoses are designed to accommodate standard or custom flange types. Other options include: inbuilt nipples, victaulic end connections and plain or cuffed ends. We custom manufacture to nominated length and offer a variety of compounds and wear liner gauges to best suit the duty and engineer to required pressure.

LINATEX SPECIALTY HOSE RANGE

The Linatex Specialty Hose range includes:

Hard Wall Mining Hose (808)

- Acid/Chemical Hose (700)
- Cut End Hose and Split Cast Couplings
- Smooth Cut End Hose (801)
- Corrugated Cut End Hose (800)
- Aluminum and Cast Iron Couplings

Soft Wall Mining Hose (806)

Dredge Hose (1000)

- Discharge Dredge Hose
- Gimble and Trunnion Hose
- Dredge Sleeves
- Custom designs by request

Flexible Connectors

- Preformed Hose Bends
- Reducers and Tapers
- Adaptors
- Expansion Pieces

At Linatex, we pride ourselves on delivering total hose solutions. We are also able to supply an extensive array of complementary hose products.

Please Note: Not all items are available in all regions. Please contact your local Linatex representative for more details and information.



Linatex Specialty Hose

HARD WALL MINING HOSE* (808)

The Linatex Hard Wall Mining Hose (808) range of custom hoses is designed for the most arduous of mining and industrial duties.

Built for delivery and suction applications, these robust hoses are manufactured with a heavy spring steel wire helix, designed to cater for high dynamic loads.

Linatex Hard Wall Mining Hose 808 can also be adapted for aggressive acid or chemical applications through the addition of Linatex Premium Rubber liners.

Linatex Hard Wall Mining Hose 808 can be custom manufactured to any size and are available with a broad array of flange types.

* Hard Wall Mining Hose (808) is also suitable for heavy duty industrial applications.

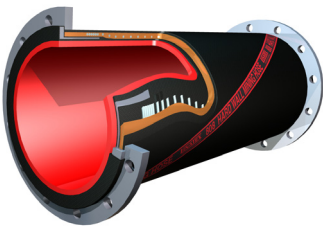

SOFT WALL HOSE (806)

The Linatex Soft Wall Hose (806) range allows for moderate flexibility and is preferred in applications where the hose is moved frequently. The non-wire construction reduces the occurrence of internal damage caused by over bending.

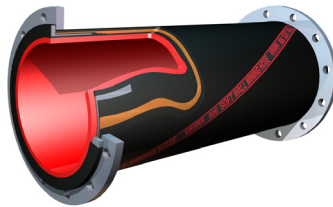

CUT END HOSE AND EXTERNAL REUSABLE COUPLINGS

The Linatex Cut End Hose coupling arrangement is designed as an 'off the shelf' hose system developed to minimise both down time and maintenance costs. Combining the outstanding abrasion resistance of a uniform wear tube with lightweight reusable aluminium flanged couplings, this unique combination allows fast and easy onsite assembly.

The hose coupling system is not exposed to the material flow and is therefore suitable for abrasive and corrosive duties. The couplings are available in either aluminium or cast iron and accommodate standard industry operational pressures.

Linatex Cut End Hose is available in both smooth and corrugated form.

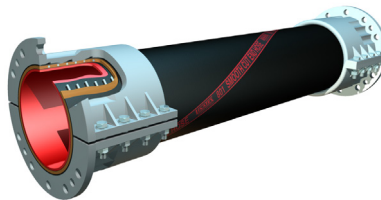

DREDGE HOSE

Linatex, globally regarded as the industry leader in abrasion resistant rubber compounds, now also has the enviable reputation as a global supplier of quality dredge hoses with a difference.

Our reputation for quality wear performance dredge hose is why Linatex hose has been trusted by many dredge operators and used on many of the world's leading dredges.

With years of compounding experience behind us, and expert, in-house engineers available to work with you, we are confident that we will provide a dredge hose solution to meet your specific requirements.

The Linatex Dredge Hose range includes both suction and discharge dredge hoses, dredge ladder hoses and dredge sleeves. Other designs are also available.

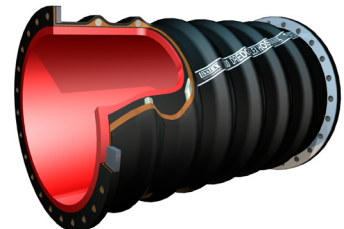

MINIMUM BENDS RADIUS

The bend radius (r) is the radius of the arc through which a hose is bent. The minimum bend radius is the tightest arc in which a hose can be bent without kinking or otherwise damaging the hose. Bending a hose to a tight radius imposes stresses on the structure of the hose that may cause a reduction in the performance, or in extreme cases permanent damage to the hose.

The minimum bend radius that a hose will withstand depends upon many factors including the wall thickness, the presence of a wire helix, the type of reinforcing material and the loss of performance that can be tolerated.

For those applications where a tighter bend radius is required, a special hose construction is employed when the bend radius is eight times the nominal bore. Hoop construction is also employed where robust flexible hose is required.

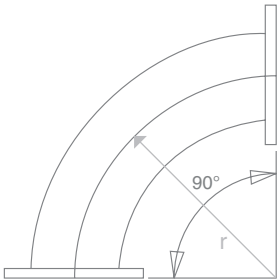

PREFORMED HOSE BENDS

Similar in construction to our Hard Wall Hose, Linatex Preformed Hose Bends are intended for use where space limitations demand a much sharper bend radius than can be achieved using a length of Linatex Hard Wall Hose (808).

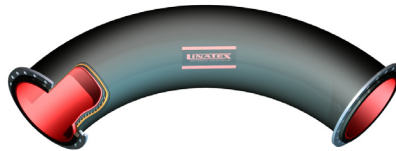

Designed to offer superior wear performance over normal hose and steel lined pipe, Linatex provides these in an extensive array of diameters, bend angles and radii configurations.

REDUCERS (TAPERS) AND ANCILLARY ITEMS

Concentric and eccentric hose reducers are built for either suction or discharge duties and are custom manufactured to incorporate differing flange requirements.

They can be manufactured to incorporate flush points and designed to custom pressure and length requirements.

As your total hose solution provider, Linatex also manufactures ancillary items such as T pieces, Y pieces, adaptors and expansion pieces.



LINATEX WEAR INDICATOR

Our unique, wireless, Wear Indicator technology provides a complete solution to many of the problems that are faced in maintaining highly abrasive materials handling hose.

Linatex Wear Indicator technology eliminates the need for physical inspections and averts costly emergency downtime. Our technology also helps to prevent unexpected hose failure which can cause environmental spills and health and safety incidents.

Linatex Wear Indicator technology even detects wear in hoses carrying conductive slurries, including those containing hyper-saline.

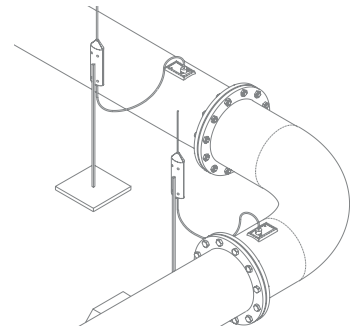

Linatex Specialty Hose

HOSE END TYPES

Fixed Flange

Fixed Flange ends are recommended for hoses that have medium working pressures and subject to low stresses during application.

The rubber and fabric reinforcement of the hose body is extended to form a full face flange which is backed by a full circle or split ring metal backing plate.



Swivel Flange

Swivel Flange ends have the ability to rotate the backing flange, and are designed as an alternative to Fixed Flange ends. Swivel Flanges allow ease of alignment of the bolt holes and the ability to rotate the hose to evenly distribute wear without removing the flanges from the adjoining pipe.

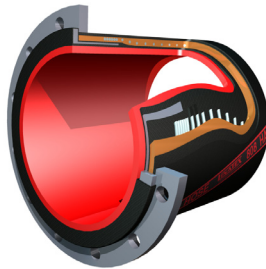

Custom Couplings

Custom Couplings are fully rubberised, inbuilt couplings that are available in Swivel or Fixed Flange configurations. Custom Couplings are mainly used in dredging and high performance/pressure slurry applications.

The inbuilt coupling tail piece is adaptable to various fittings, including victaulic, rotating, Fixed Flanges and propriety couplings.

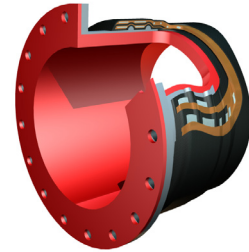

Double Flanges

The Double Flange arrangement is designed for use on hoses subject to high axial loads. The twin steel flanges are built in and able to withstand considerable bend loads while maximising flexibility from the hose. The front flange is encapsulated in rubber and reinforcement cord, providing protection against corrosion.



Cut End and External Reusable Coupling

This two-piece External Coupling is designed for use on Linatex cut end hose. The coupling does not come into contact with the internal hose flow, making it highly suitable for abrasive slurries.

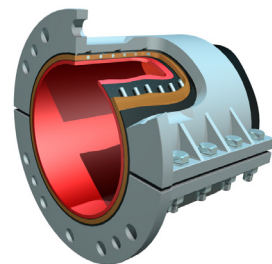

Linatex Specialty Hose

THE LINATEX DIFFERENCE

Linatex is proud to be the market leader. We set the international benchmark for rubber used for abrasive materials handling across all mining applications.

Linatex are not just leading the way in the mining industry, we are also suppliers of premium hose and end fittings for other industries. Linatex dredge flex hose is the equal of any dredge hose in the field. When our solution focused engineering capabilities are taken into consideration, Linatex becomes the **only** option when selecting dredge hose for your operation.

By imposing strict quality control measures and testing samples at every step of production, Linatex ensures long lasting industrial wear solutions that are the most cost effective. With hose available in either renowned Linatex Rubber or a variety of compounds, we deliver the right hose for every job.

Superior design capabilities and build quality, as well as our customer service, is what sets Linatex hose apart. When you invest in Linatex hose, you get more than just a hose, you receive a product that is made from the best raw materials, custom engineered to your exact requirements and backed up by our ongoing, onsite technical support.

Our unique Wear Indicator technology demonstrates our commitment to harnessing technological innovations to make your job easier and your site safer.

Global production facilities allow us to meet short manufacturing lead times and our extensive distribution network ensures prompt delivery, no matter where you are.

In a diverse range of materials handling applications, Linatex Rubber hose products have proven to consistently outperform and outlast competitor products. To find out more, read about our in-the-field success stories at www.linatex.com

For more information about the Linatex Specialty Hose range, please refer to our comprehensive range of hose product specification sheets or contact your local Linatex representative.

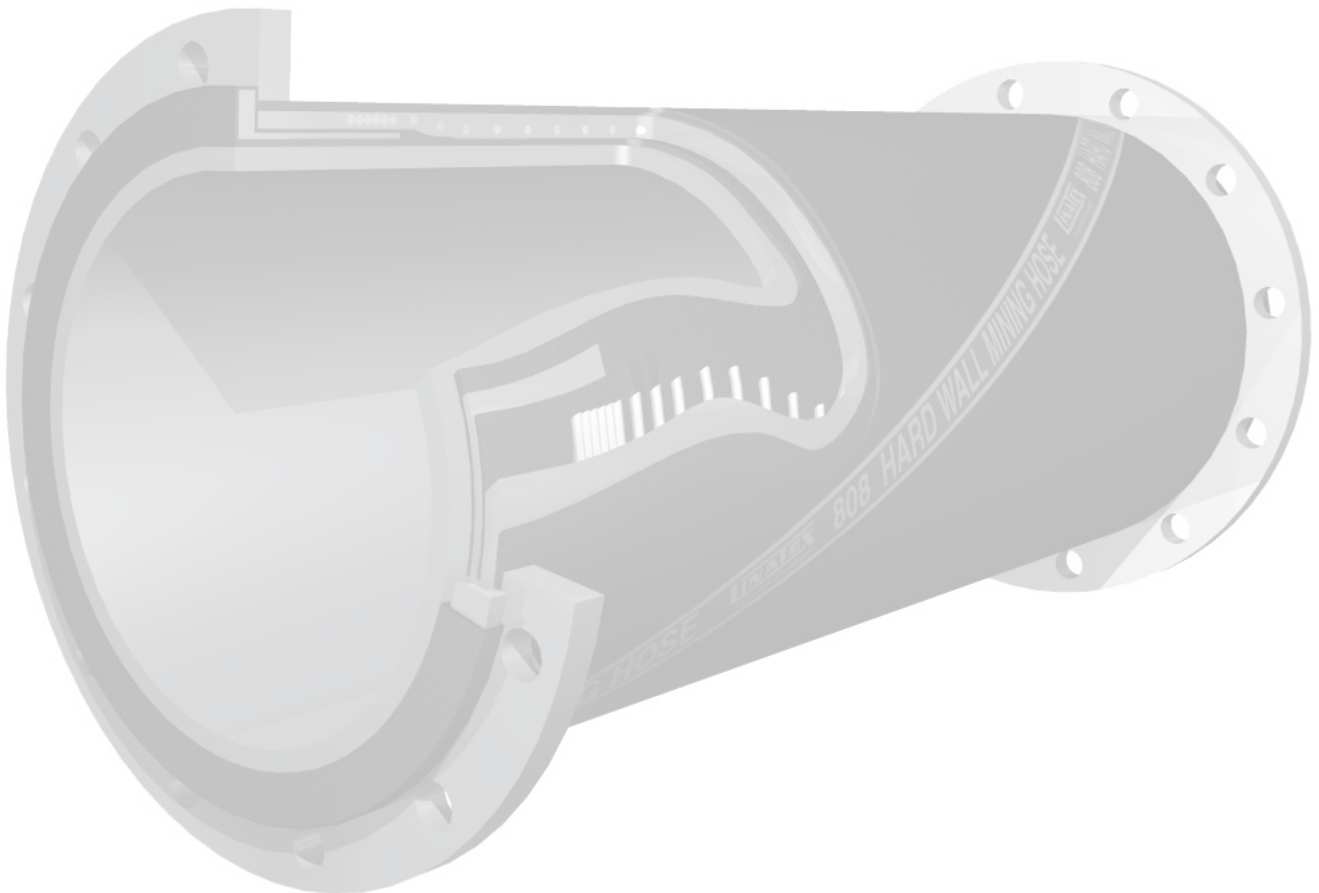



PROCESS
EQUIPMENT

Combining superior abrasion resistance with integrated processing systems, the Linatex process equipment line includes valves, hard metal and rubber pumps, dewatering screens, and hydrocyclones - each lined with Linatex premium rubber for maximum wear life - and custom engineered to industries such as aggregate, mining, oil sands production, and water treatment and clarification.



SHEET

Utilising our unique proprietary process, the Linatex range of rubber products comprise premium cured or uncured natural rubbers; carbon black and/or silica reinforcements; and numerous compound bases such as nitrile, neoprene and bromo butyl - all field-proven to outlast steel and conventional synthetic rubbers and polyurethane in a variety of heavy duty, high impact and highly abrasive wet or dry applications - while ensuring the lowest cost of ownership due to unparalleled strength, resilience and abrasion resistance.



MOULDED

Custom-fabricated to exact specifications and manufactured in any shape or configuration, Linatex moulded components meet the needs of virtually any industry requiring superior wear resistant parts performance in any application - even those involving high temperatures, oils, chemicals, acids and other highly corrosive materials.



SCREEN
MEDIA

Offering complete separating and sizing solutions backed by meticulous applications analysis, the Linatex range of screen media (manufactured and supplied by our fully-owned subsidiary, Durex Products, Inc.) maximises capacity and cost efficiency, and minimises maintenance and downtime - with innovations that surpass conventional alternatives in preventing plugging, pegging and blinding in tough applications - whether wet, dry, sticky or highly abrasive.



HOSE

Adaptable and compatible to limitless applications, Linatex custom-made material handling hose is engineered with an array of reinforcement cords and end connections, and a wear liner composition specifically formulated for the application - all available within a product range that includes slurry and chemical mining hose, dredge hose and a wide variety of preformed bends, reducers and T-pieces.



SERVICE

Linatex offers reliable and responsive onsite service and parts support as well as turnkey engineered solutions - from the initial onsite consultation, applications analysis and testing, through to design, manufacturing, installation, commissioning and ongoing maintenance - bringing together world class expertise with in-depth knowledge of local culture and practices.

HEAD OFFICE - MALAYSIA

MALAYSIA

Commercial Division - Asia
6 ½ Mile Jalan Ipoh, 68100 Batu Caves,
Selayang, Selangor, Darul Ehsan,
Malaysia
T: +60 3 6251 7888
F: +60 3 6255 2173

LINATEX ASIA PACIFIC

CHINA

10th Floor, Room 1007, Eton Place
No 69 Dongfang Road
Shanghai 200120
People's Republic of China
T: +86 21 5882 7366
F: +86 21 5882 7377

MELBOURNE

61-63 Camberwell Road
Hawthorn East, VIC 3123
Australia
T: +61 3 9834 7400
Sales: +61 3 9706 6568
F: +61 3 9834 7405

TOWNSVILLE

688 Ingham Road
Bohle, QLD 4818
Australia
T: +61 7 4758 6100
F: +61 7 4758 6111

PERTH

30-36 Wittenberg Drive
Canning Vale, WA 6155
Australia
T: +61 8 9256 8300
F: +61 8 9256 8305

LINATEX AFRICA

SOUTH AFRICA

5 Fuchs Street
Alrode
1449, Gauteng
South Africa
T: +27 11 617 4800
F: +27 11 908 1644

Mabe Business Park
Unit 5, Delta Road
Waterfall East
South Africa
T: +27 14 592 1538
F: +27 14 592 9870

LINATEX EUROPE

UNITED KINGDOM

Wilkinson House
Galway Road
Blackbushe Business Park
Yateley, Hampshire
GU46 6GE, United Kingdom
T: +44 1252 743000
F: +44 1252 743030

RUSSIA

125040
Moscow
Skakovaya 9, 5th Floor, Office 525
Russia
T: +7 495 945 2795
F: +7 495 945 2781

LINATEX THE AMERICAS

TENNESSEE

1550 Airport Road
Gallatin, TN 37066
USA
T: +1 615 230 2100
F: +1 615 230 2101

WISCONSIN

112 First Avenue West
Luck, WI 54853
USA
T: +1 715 472 2111
Toll Free: 800 826 6931
F: +1 715 472 2115

QUEBEC

372 Avenue Noël
Sept-Îles
Quebec G4R 1L7
Canada
T: +1 418 968 2822
F: +1 418 962 9221

ONTARIO

343 Whitewood Ave
New Liskeard
Ontario POJ 1PO
Canada
T: +1 705 647 4476
F: +1 705 647 0144

CHILE

Santa Catalina de Chena 850
Parque Industrial Estrella Del Sur
San Bernardo, Santiago
Chile
T: +56 2 387 9400
F: +56 2 387 9401