

# Silver Series

## SS3x2-000010

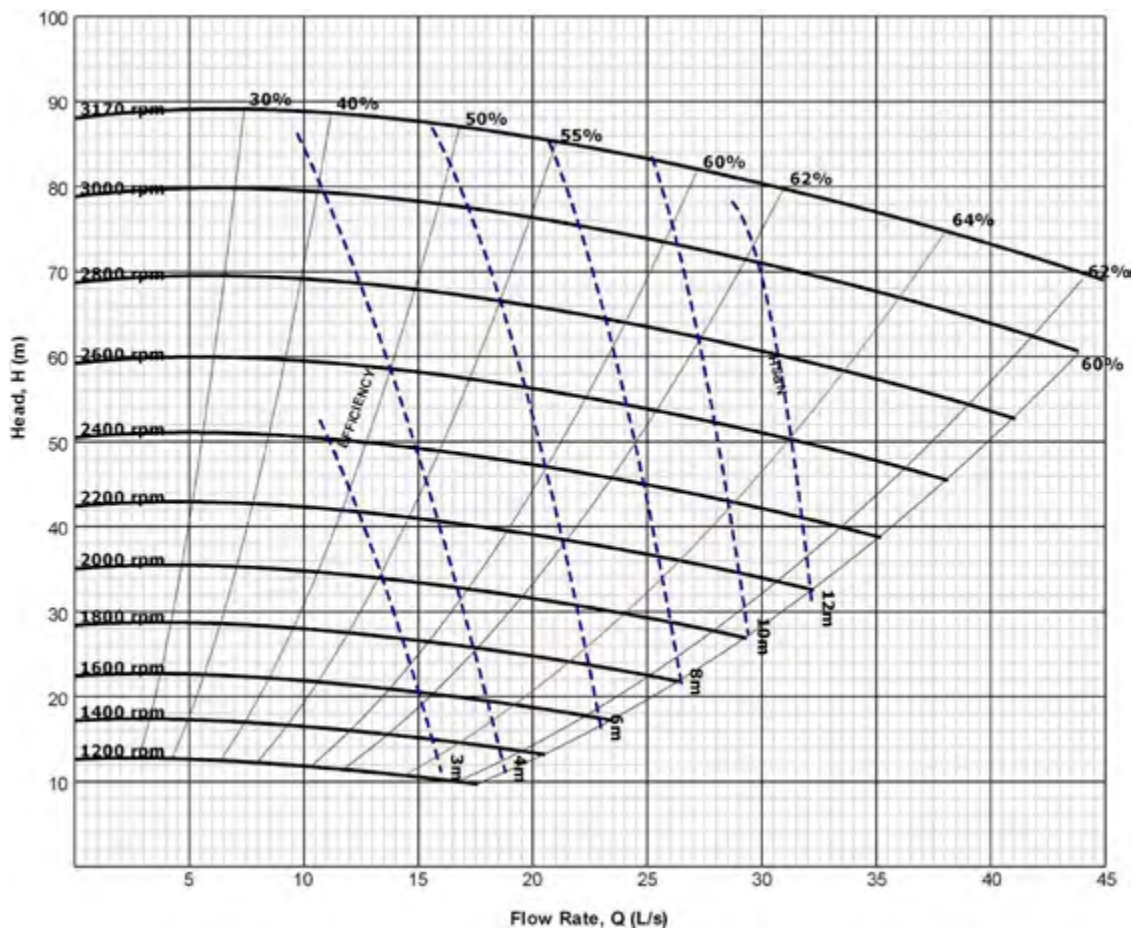

<b>Suction</b>	76.2 mm (3")
<b>Discharge</b>	50.8 mm (2")
<b>Maximum RPM</b>	3170
<b>Sealing system</b>	Standard gland packing
<b>Liner material</b>	High chrome
<b>Impeller material</b>	High chrome
<b>Throat bush</b>	N/A
<b>Maximum motor power</b>	30 kW
<b>Weight-Bare shaft pump</b>	197 kg



**NOTE** This information is for guidance/reference only. For application specific drawings and curves, please contact your nearest authorised distributor at [slurrypro.com](http://slurrypro.com)

## Silver Series

### SS3x2-000010

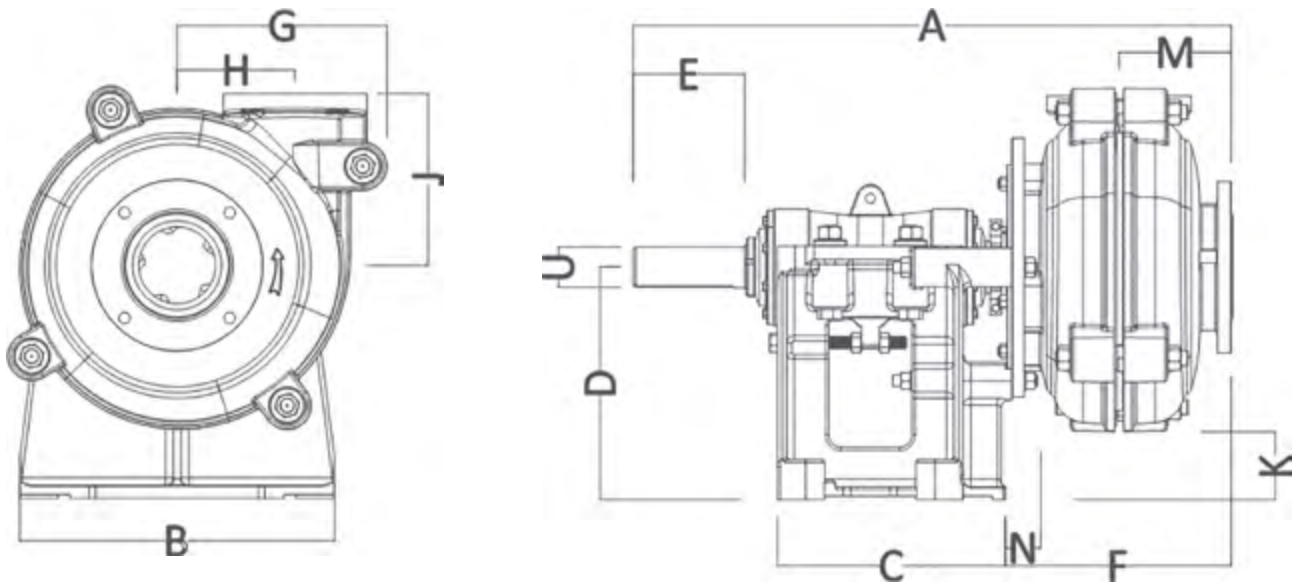

A	B	C	D	E	F	G	H
768.1	405.89	310.9	254	120.9	279.91	238	137.92
J	K	L	M	N	U	Key size	
210.06	71.37	0	150.88	39.62	42	12 x 8	

All values in millimetres (mm)