

Silver Series

SS2x1.5-01000

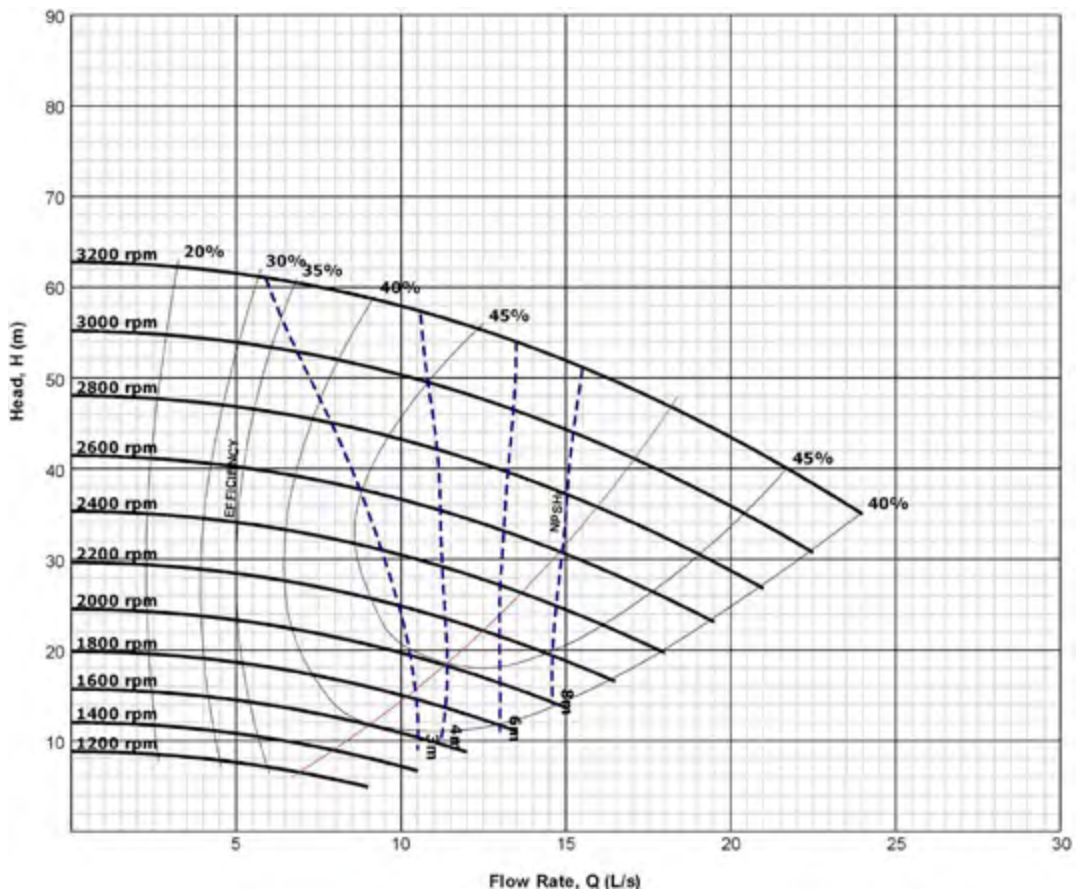

Suction	50.8 mm (2")
Discharge	38 mm (1.5")
Maximum RPM	3200
Sealing system	Standard gland packing
Liner material	High chrome
Impeller material	High chrome
Throat bush	N/A
Maximum motor power	15 kW
Weight-Bare shaft pump	156 kg



NOTE This information is for guidance/reference only. For application specific drawings and curves, please contact your nearest authorised distributor at slurrypro.com

Silver Series

SS2x1.5-01000

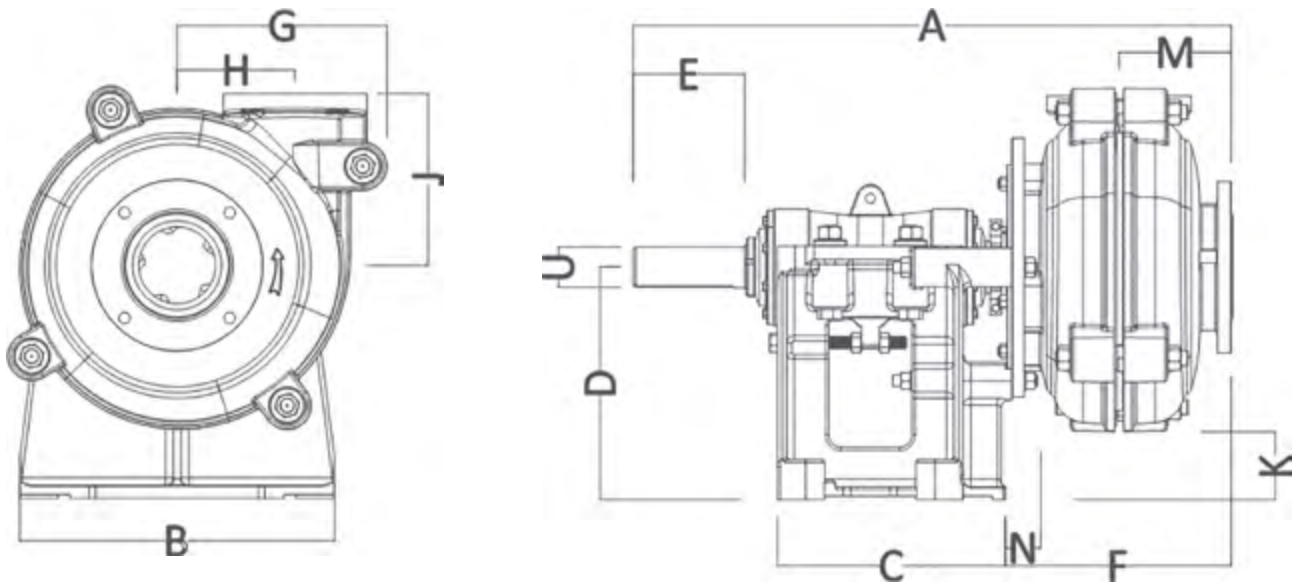

A	B	C	D	E	F	G	H
592.07	294.89	247.9	197.1	78.99	216.92	202.95	114.05
J	K	L	M	N	U	Key size	
183.9	33.27	0	114.05	21.84	28	8 x 7	

All values in millimetres (mm)